

C003Cd

CAMPANA INDUSTRIAL SATURNO 150W CW 0-10V

- Cuerpo de aluminio puro extruido.
- Difusor opal de policarbonato de alta calidad.
- Garantía: 5 años - Ampliable



150 W



140 lm/W

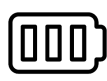

100000 h



>84



IP65



IK08



<22



1-10V



120°



-40 / 50 °C

APLICACIONES



DEPORTIVA



INDUSTRIAL



COMERCIAL

www.axoled.com

AXOLED S.L. Polígono Industrial Les Masses
C/ Almansa 3 · 46725 Ròtova · Valencia
Contacto: +34 962 965 765 · info@axoled.com

Las especificaciones están sujetas a cambios sin previo aviso.

© Axoled, 2022. Todos los derechos reservados.



DATOS TÉCNICOS

Flujo lumínico	21.000 lm
Intensidad luminosa máxima:	7.368 cd
Eficacia luminosa	140 lm/W
Color lámpara/aplicación	Blanco frío
Temperatura de color	5.700 K
Índice de reproducción cromática	>84
Parpadeo	Sin parpadeo
Grado de deslumbramiento	UGR <22
Ángulo de apertura	120 °
Tipo LED	NICHIA
Número de LEDs	147
Agrupamiento MacAdam	2
Simetría óptica	Simétrica
Distribución óptica	Directa

DATOS ELÉCTRICOS

Potencia consumida	150 W
Grado protección IP	IP65
Grado protección IK	IK08
Factor de potencia	0,95
Vida	100.000 h L80B10
Tensión	230 - 240 V
Frecuencia	50 - 60 Hz
Clase de aislamiento	Clase I

DATOS DIMENSIONALES

Tipo de instalación	Suspendida/Superficie
Formato	Circular
Largo exterior	260 mm
Alto/Fondo	208 mm
Peso	4,50 Kg

CARACTERÍSTICAS

Material	Aluminio
Material del difusor	PMMA - Opal
Tipo driver/equipo	MeanWell
Regulación	1-10V
Temperatura de funcionamiento	-40 ~ 50 °C

EFICIENCIA ENERGÉTICA

Tipo de producto	Fuente luminosa
Clasificación energética	D
Número de registro EPREL	1301381

CUMPLIMIENTO NORMATIVAS

Marcado CE	Si
Conforme RoHS	Si
Reciclable	Si

www.axoled.com

AXOLED S.L. Polígono Industrial Les Masses
 C/ Almansa 3 · 46725 Ròtova · Valencia
 Contacto: +34 962 965 765 · info@axoled.com

Las especificaciones están sujetas a cambios sin previo aviso.

© Axoled, 2022. Todos los derechos reservados.



DESCRIPCIÓN EXTENDIDA

Campana industrial Led con diseño exclusivo de compactas dimensiones y reducido peso. Se puede instalar adosada, suspendida o con soporte tipo lira. Cuerpo de aluminio puro extruido. Difusor opal de policarbonato de alta calidad.

MEDIDAS EN mm

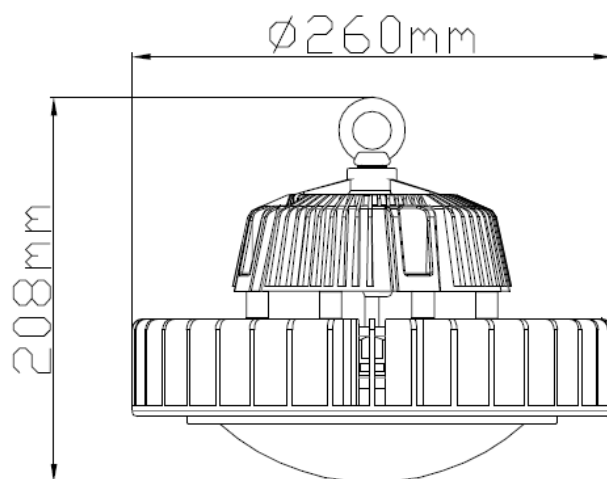

ÓPTICAS

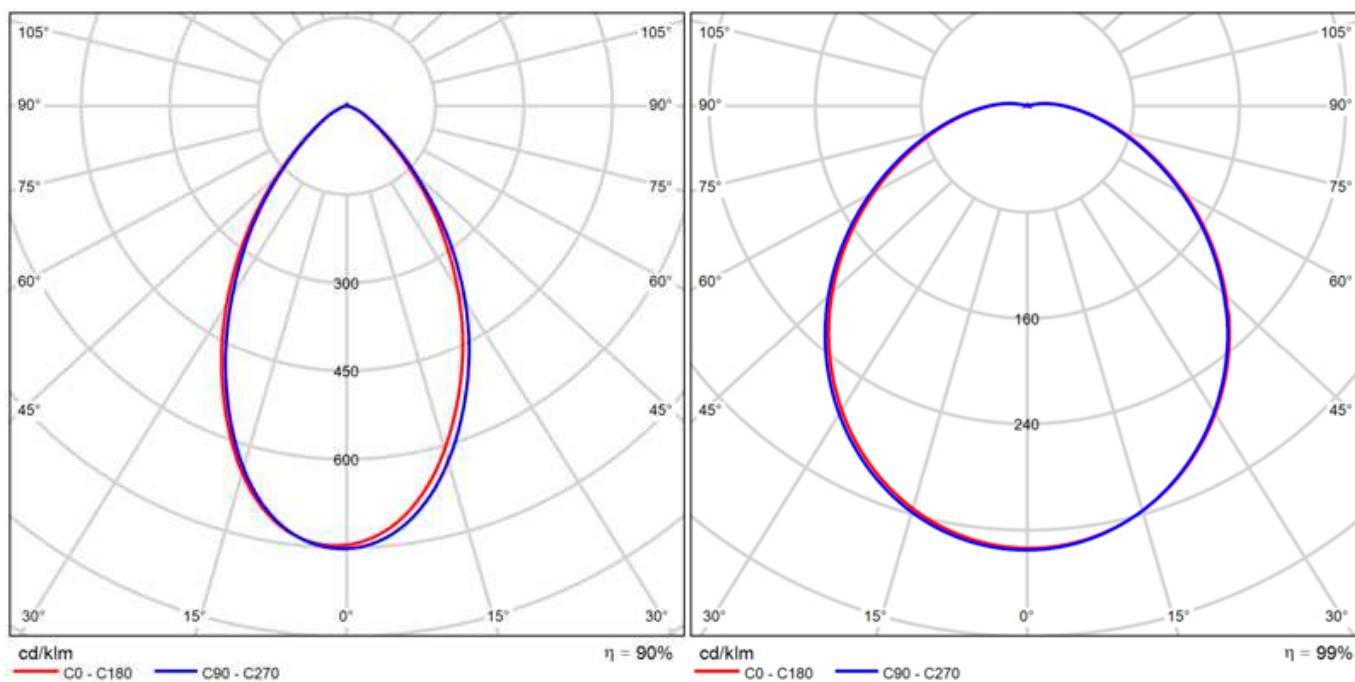

www.axoled.com

AXOLED S.L. Polígono Industrial Les Masses
C/ Almansa 3 · 46725 Ròtova · Valencia
Contacto: +34 962 965 765 · info@axoled.com

Las especificaciones están sujetas a cambios sin previo aviso.

© Axoled, 2022. Todos los derechos reservados.



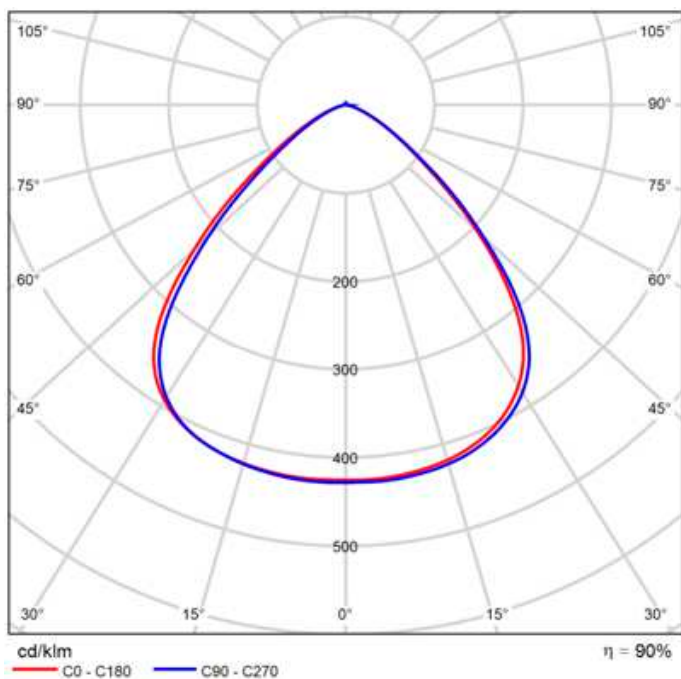

FOTOS



ENLACES/DESCARGAS



www.axoled.com

AXOLED S.L. Polígono Industrial Les Masses
C/ Almansa 3 · 46725 Ròtova · Valencia
Contacto: +34 962 965 765 · info@axoled.com

Las especificaciones están sujetas a cambios sin previo aviso.
© Axoled, 2022. Todos los derechos reservados.



ACCESORIOS

Imagen	Referencia	Descripción	Cantidad
	CA003 ↓	Reflector 60º Campana SATURNO de 100W a 200W	1
	CA000 ↓	Reflector 90º Campana SATURNO de 100W a 200W	1
	CA005 ↓	Soporte Lira Acople Pista Padel	1
	Q909i ↓	CONVERSOR DE 0/10 A DALI	1